

**PLEASE KEEP THIS MANUAL
FOR FUTURE REFERENCE**

WARNING!

**IF THE INFORMATION IN THIS
MANUAL IS NOT FOLLOWED
EXACTLY, A FIRE OR EXPLOSION
MAY RESULT CAUSING PROPERTY
DAMAGE, PERSONAL INJURY OR
LOSS OF LIFE.**

FOR YOUR SAFETY

WHAT TO DO IF YOU SMELL GAS

- Do not try to light any appliance.
- Do not touch any electric switch; do not use.
- Immediately call your gas supplier from your neighbours phone. follow the gas suppliers instructions.
- If you can not reach your gas supplier, call the fire department (911)
- Open window/extinguish all flames.

Installations and service must be performed by a qualified installer, service agency or your gas supplier.

Do not store or use gasoline or other flammable vapours and liquids in the vicinity of this or any other appliance.

This appliance may be installed as an OEM installation in a manufactured (mobile) home and must be installed in accordance with the manufacturer's instructions and the manufactured home construction and safety standard, *Title 24 CFR, Part 3280* or *Standard for Installation in Mobile Homes, CAN/CSA Z240 MH*.

This appliance may be installed in an aftermarket permanently located, manufactured (mobile) home, where not prohibited by local codes

This appliance is only for use with the type of gas indicated on the rating plate. This appliance is not convertible for use with other gases, unless a certified kit is used.



THE AUTHENTIC ORIGINAL

DIRECT VENT GAS STOVE

**INSTALLATION AND OPERATING
INSTRUCTIONS**

MODEL: DRAGON/700



Dragon Model



700 Model



Report No: 224-S-03-5

ATTENTION CONSUMERS

In order to ensure safe and effective installation, this unit must be installed only by a qualified agency, individual, firm, corporation, or company that is experienced in the installation, repair and servicing of this type of appliance and is familiar with the building codes and installation techniques appropriate in your area. Contact your hearth products dealer or local gas supplier for the name of a qualified service person.

INSTALLERS

Please read this manual carefully before you begin installation procedures. Failure to follow instructions may result in property damage, bodily injury or loss of life.

This manual contains important user information.

Keep this manual with the fireplace after installation is complete.

ATTENTION

The stove is shipped from the factory as a direct vent natural gas freestanding room heater. To convert to propane please follow the directions in this manual. All conversions must be carried out by a qualified agency, individual, firm, corporation or company that is experienced in installations and repairs.

General Information	page 4
Venting requirements	page 8
Vent termination clearances	page 9
Assembly procedures	page 13
Installing the log set	page 17
Operation	page 19
Lighting and operating instructions	page 20
Remote control	page 21
Maintenance	page 23
Dragon/700 components	page 25
Contacting ESSE	page 26

The Dragon/700 Direct Vent Room Heater, is a vented gas appliance listed to the ANSI standard Z21.88-2002 and CSA-2.33-2002 for Vented Room Heaters, and CSA 2.17-M91, Gas Fired Appliances For Use at High Altitudes.

The installation of the Dragon/700 Direct Vent Room Heater must conform with local codes, or in the absence of local codes, with National Fuel Gas Code, ANSI Z223.1 – latest edition and CSA B-149.1 Installation Code.

This appliance is only for use with the type of gas indicated on the rating plate. This appliance is not convertible for use with other gases unless a certified kit is used.

Installation and replacement of gas piping, gas utilization equipment or accessories, and repair and servicing of equipment shall be performed only by a qualified agency. The term “qualified agency” means any individual, firm, corporation, or company that either in person or through a representative is engaged in and is responsible for (a) installation or replacement of gas piping, or (b), the connection, installation, repair, or servicing of equipment, who is experienced in such work, familiar with all precautions required, and has complied with all the requirements of the authority having jurisdiction.

The Dragon/700 Direct Vent Room Heater should be inspected before use and at least annually by a qualified service agency. It is imperative that control compartments, burners, and circulating air passageways of the appliance be kept clean.

The Dragon/700 Direct Vent Room Heater and its individual shut-off valve must be disconnected from the gas supply piping during any pressure testing of that system at test pressure in excess of 1/2 psig (3.5 kPa).

The Dragon/700 Direct Vent Room Heater must be isolated from the gas supply piping system by closing its individual manual shut-off valve during any pressure testing of the gas supply piping system at test pressures equal to or less than 1/2 psig.

‘Direct Vent’ describes a sealed combustion system in which incoming outside air for combustion and outgoing exhaust enter and exit through two separate concentric passages within the same sealed vent system. The system does not use room air to support combustion. The Direct Vent system permits the gas appliance to be vented directly to the outside atmosphere through the side of the house or vertically through the roof.

Conventional venting systems (Natural Vent) take air from the room for combustion and vent the exhaust vertically through the roof to the atmosphere.

This appliance is approved for bedroom installations in the U.S. and Canada.

This appliance may be installed in an aftermarket* manufactured (mobile) home, where not prohibited by state or local codes.

WARNING Operation of this heater when not connected to a properly installed and maintained venting system can result in carbon monoxide (CO) poisoning and possible death.

Due to high temperatures this appliance should be located out of traffic and away from furniture and draperies.

WARNING This appliance is hot while in operation. Keep children, clothing, and furniture away. Contact may cause burns or ignition of combustible materials.

Children and adults should be alerted to the hazards of high surface temperatures and should stay away to avoid burns or clothing ignition. Young children should be carefully supervised when they are in the same room as the appliance.

Clothing or other flammable materials should not be placed on or near the appliance. Any safety screen, glass or guard removed for servicing an appliance must be replaced prior to operating the appliance.

Installation and repair should be done by a qualified service person. The appliance should be inspected before use and at least annually by a professional service person. More frequent cleaning may be required due to excessive lint from carpeting, bedding material, et cetera. It is imperative that control compartments, burners and circulating air passageways of the appliance be kept clean.

The appliance area must be kept clear and free from combustible materials, gasoline, and other flammable vapors and liquids.

The flow of combustion and ventilation air must not be obstructed. The installation must include adequate accessibility and clearance for servicing and proper operation.

WARNING Do not operate the Room Heater with the glass panel removed, cracked or broken. The glass panel is fragile and should not be abused, struck or slammed shut. See “Maintenance” section for cleaning instructions. Replacement of the glass panel should be done by a licensed or qualified service person. Do not use this appliance if any part has been under water. Immediately call a qualified service technician to inspect the appliance and to replace any part of the control system and any gas control which has been under water.



Do not burn wood, trash or any other material for which this appliance was not designed. This appliance is designed to burn either natural gas or propane only.

This gas appliance must not be connected to a chimney flue serving a separate solid-fuel burning appliance.

Verify proper operation after servicing.

Proposition 65 Warning: Fuels used in gas, wood burning or oil fired appliances, and the products of combustion as such fuels, contain chemicals known to the state of California to cause cancer, birth defects and other reproductive harm.

California Health & Safety Code Sec. 25249.6

***Aftermarket:** Completion of sale, nor for purpose of resale, from the manufacturer.

**DRAGON/700 DIRECT VENT GAS HEATER NATURAL GAS AND LIQUID PROPANE:
DRAGON/700DIRECT VENT CERTIFIED TO: ANSI Z21.88-2002 /CSA 2.33-2002
VENTED GAS FIREPLACE HEATERS**

Fuel	NG	LP
Manifold Pressure – Min/Max	1.3" / 3.5"	3.6" /10.5"
Min. Inlet Supply Pressure For Adjustment	4.5" W.C.	11" W.C.
Max. Inlet Supply Pressure For Adjustment:	7.0" W.C.	14.0" W.C.
Input btu/h (Max)	26,500	23,000
Input btu/h (Min)	16,500	12,700
Ignition:	Piezo	Piezo
Burner Orifice Size:	82/800	92/260

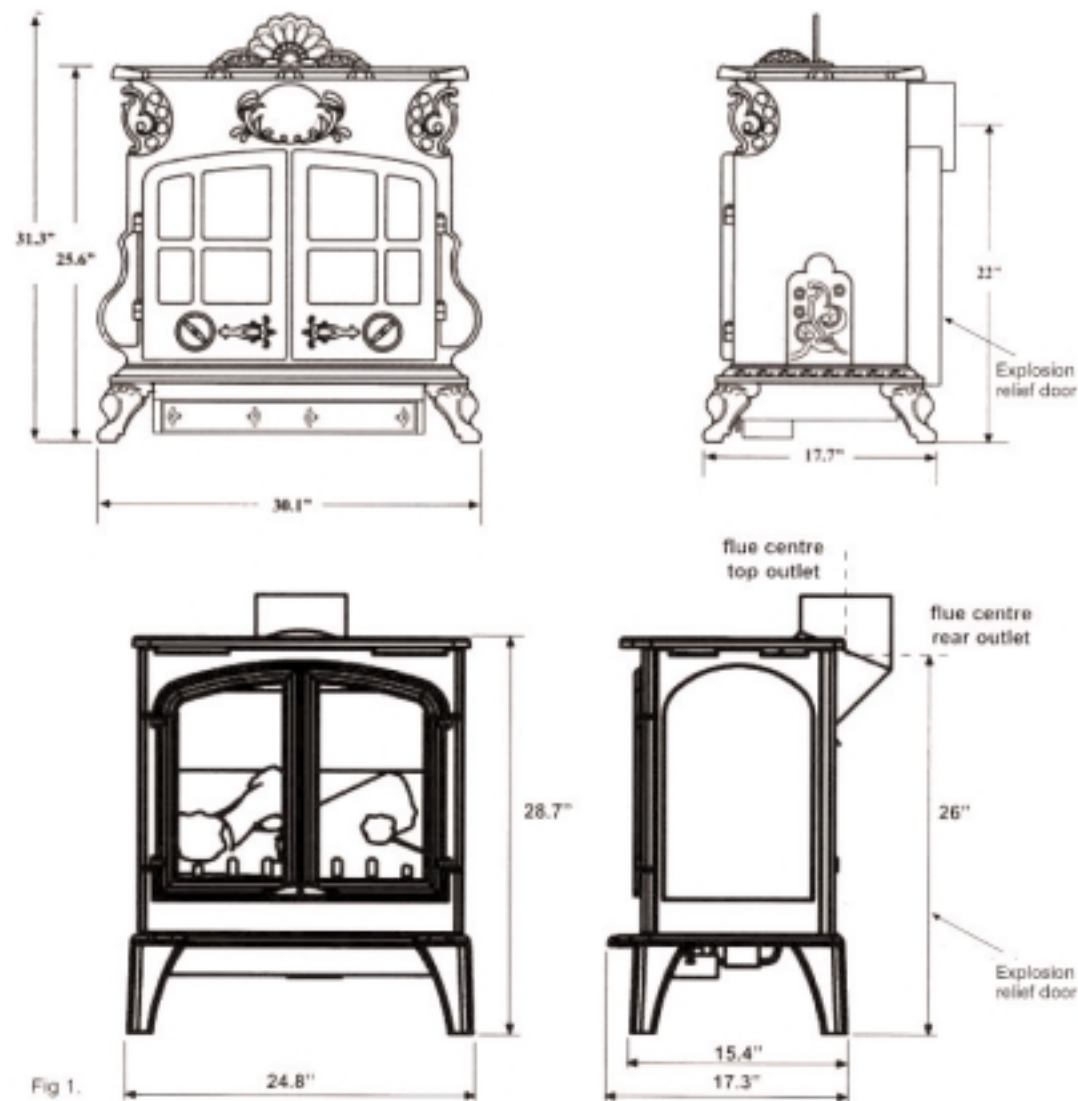

The installation of your ESSE stove must conform with local codes, or in the absence of local codes, with the National Fuel Gas Code ANSI Z223.1 – latest edition, or CSA B149.1 Installation Code.

The installation should be done by a qualified service person who is familiar with the building codes and installation techniques appropriate for your area to accomplish a safe and effective installation.

Warning: Due to high temperatures, the heater should be located out of traffic and away from furniture and draperies. The surface of the heater is hot when it is in use. Young children should be watched carefully when they are in the same room when the heater is in use. Observe the recommended clearances that follow.

The Dragon/700 Heater must be installed on rigid flooring. When the heater is installed directly on any combustible surface other than wood flooring, a metal or wood panel extending the full width and depth of the unit must be used as a hearth.

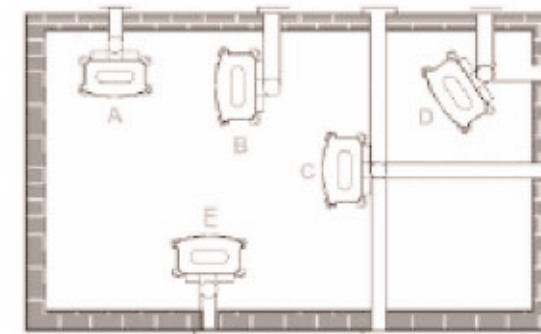

Fig. 2

Direct Vent System Only

- A. Flat on corner wall
- B. Room divider
- C. Island
- D. Cross corner
- E. Flat on wall

The Dragon/700 Heater will heat nearby surfaces when operating. A safe installation requires that adequate clearance be maintained between the stove and nearby combustible materials to ensure that such materials do not overheat. The diagrams that follow illustrate the minimum clearances for the appliance in parallel, corner and alcove installations.

Minimum clearances to combustible materials measure side clearances as shown in figures 3 and 5 from the outer edge of the cast iron stove top. Measure the rear clearances from the outermost surface of the steel rear skirt. The Dragon/700 is approved for alcove installation (see figure 6.)

In choosing a location for the stove, consider:

- the location of the outside wall.
- where additional heat is needed.
- where family members gather most often.
- the vent system requirements.

Note We do not recommend the use of wallpaper next to this stove. Over time, radiant heat may cause the wallpaper to shrink, or may adversely affect the binders in the wallpaper adhesive.

Venting Requirements

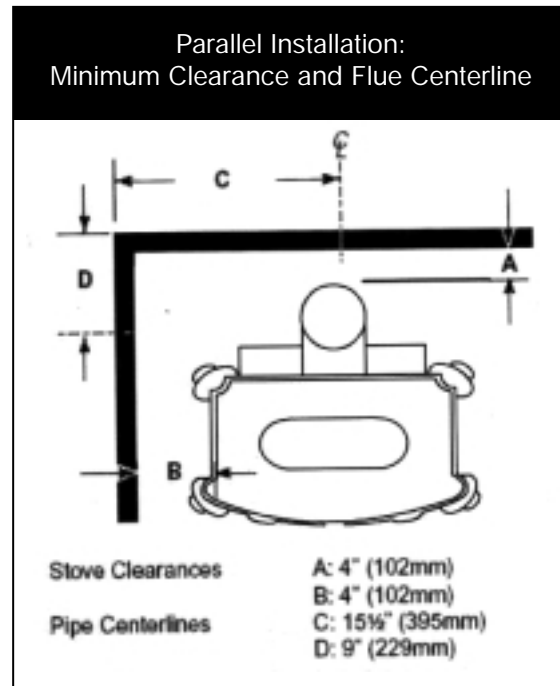

Fig 3. Parallel installation, minimum back and side clearances, and flue centrelines.

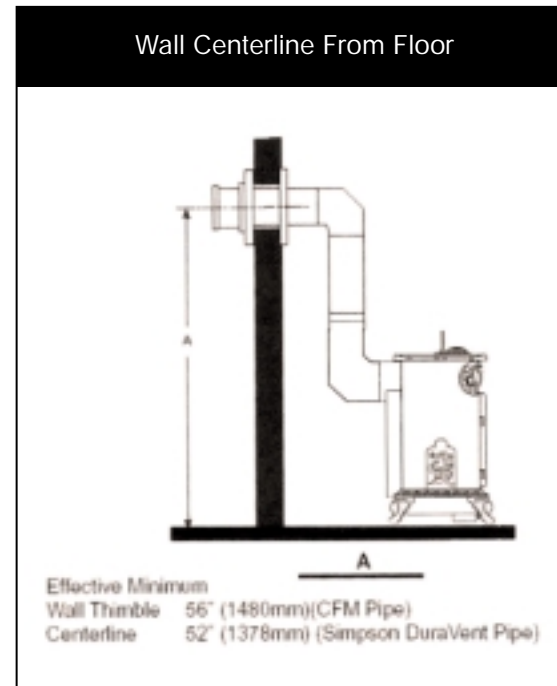

Fig 4. Minimum wall thimble centreline.

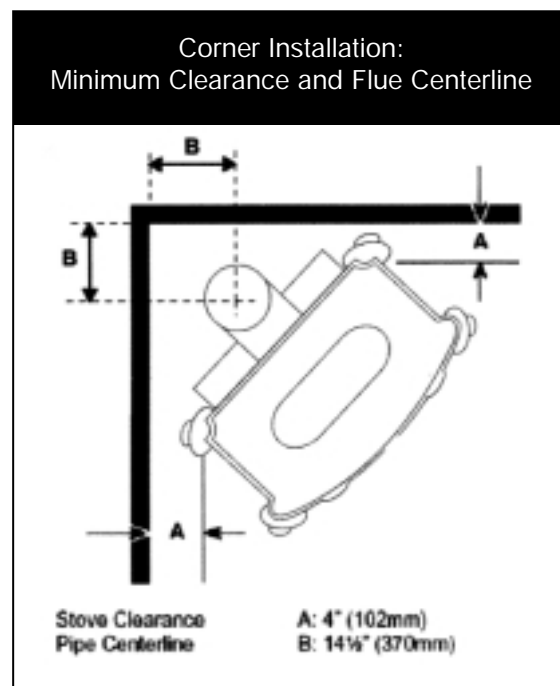

Fig 5. Corner Installation, minimum clearance and flue centerline.

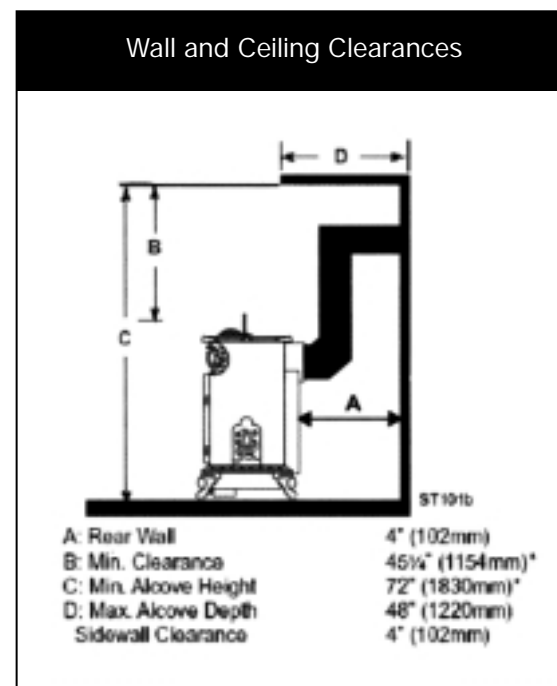

Fig 6. Dimensions and clearances to ceiling or alcove.

Approved Dragon/700 Vent System Components

The Dragon/700 heater must be vented to the outdoors through an adjacent exterior wall or through the roof. The venting system must be comprised of the appropriate listed venting components specified on this page. These parts are available from Duravent or Selkirk corporations or your ESSE dealer.

SIMPSON DURAVENT COMPONENTS:

90° ELBOW, BLK	990B
45° ELBOW, GAL	945
6" STRAIGHT, BLK	908B
9" STRAIGHT, BLK	907B
11"-14" ADJUSTABLE STRAIGHT SECTION	911B
12" STRAIGHT	906
24" STRAIGHT	904B
36" STRAIGHT	903B
48" STRAIGHT	902
HORIZONTAL VENT CAP	984
WALL PLATE	940
VINYL SIDING SHIELD	950
SNORKEL TERMINATION 14"	982
SNORKEL TERMINATION 36"	981
WALL STRAP	988
CATHEDRAL CEILING SUPPORT BOX	941
STORM COLLAR	953
FIRESTOP SPACER	963
FLASHING 0/12 - 6/12	943
FLASHING 6/12 - 12/12	943S
VERTICAL TERMINATION CAP	991

All Duravent straight vent pipe sections have a net length 1.5" (37mm) less than the nominal dimension. I.e., a 6" (152mm) straight pipe section has an effective length of 4.5" (115mm).

Direct Vent Horizontal Termination

The maximum horizontal run with no vertical rise and no snorkel kit is 12" plus the starter elbow and vent termination. If a snorkel kit is fitted then the maximum horizontal run can be extended up to 24". The horizontal run may extend up to 20' (6m) and include a vertical rise of up to 30' (9m). Horizontal termination must also meet the criteria shown in figures 4 and 8.

Direct Vent Vertical Termination

A vertical vent system must terminate no less than 8' (2.44m) and no more than 30'

1. No more than 3 90° elbows may be used.
2. Two 45° elbows may be substituted for one 90° elbow. no more than six elbows may be used.
3. Termination height must conform to roof clearance as specified in figure 7.

NOTE: 2 restrictor plates are supplied:-

- 1 - 2" Diameter
- 1 - 2 1/4" Diameter

Fit the correct restrictor plate as shown in Fig 12 in accordance with Fig 7.

When planning the installation, consider the location of the vent terminal and clearances. Some of the most common clearances to keep in mind are shown in Figure 3.

IMPORTANT All vent clearances must be maintained. Check your vent termination clearances against Fig. 8 & 9.

The vent should be placed so that people cannot be burned by accidentally touching the vent surfaces when the stove is operating. The vent termination should be located where it cannot be damaged by such things as automobile doors, lawn mowers or snow blowers and it should be located away from areas where it could become blocked by snow etc.

Some considerations are:

- Obstructions or impediments to venting.
- Nearby combustible materials that could come into contact with combustible exhaust gases.
- Other nearby openings (within 12" (305mm)) through which exhaust gas could re-enter the building.
- All vegetation within 3' (76mm) that may interfere with the draft. Other factors that influence where the installation will be sited include the location of outside walls, where additional heat may be desired in the home, where the family members gather most regularly and perhaps most importantly, the distance limitations of the venting system.

IMPORTANT!

- The horizontal termination must not be recessed into the exterior wall or siding.
- Horizontal vent runs must be level toward the vent termination.
- Clearances around the vent termination must be maintained.
- For installations using Simpson DuraVent pipe, parallel installations with minimum wall clearance have restricted access for connecting the Horizontal Vent Cap straps to the vent pipe. See the maker's instructions for recommended installation procedures.

Fig. 7

Up to 12FT	No Restrictor
12 FT to 24 FT	2 1/4" Restrictor
24 FT to 30 FT	2" Restrictor

Vent Termination Clearances

Your stove is approved to be vented either through the side wall, or vertical through the roof.

- Minimum clearances between vent pipes and combustible materials are one (1") inch (25mm), except where stated otherwise.
- Venting terminals shall not be recessed into a wall or siding.
- Horizontal venting must be installed on a level plane without an inclining or declining slope.

Location of Vent Termination

There must not be any obstruction such as bushes, garden sheds, fences, decks or utility buildings within 24" from the front of the termination hood. Do not locate termination hood where excessive snow or ice build up may occur. Be sure to check vent termination area after snow falls, and clear to prevent accidental blockage of venting system. When using snow blowers, make sure snow is not directed towards vent termination area.

IT IS IMPERATIVE THE VENT TERMINATION BE LOCATED OBSERVING THE MINIMUM CLEARANCES AS SHOWN ON THE NEXT PAGE.

Figure 8 - Vent Terminal Clearances

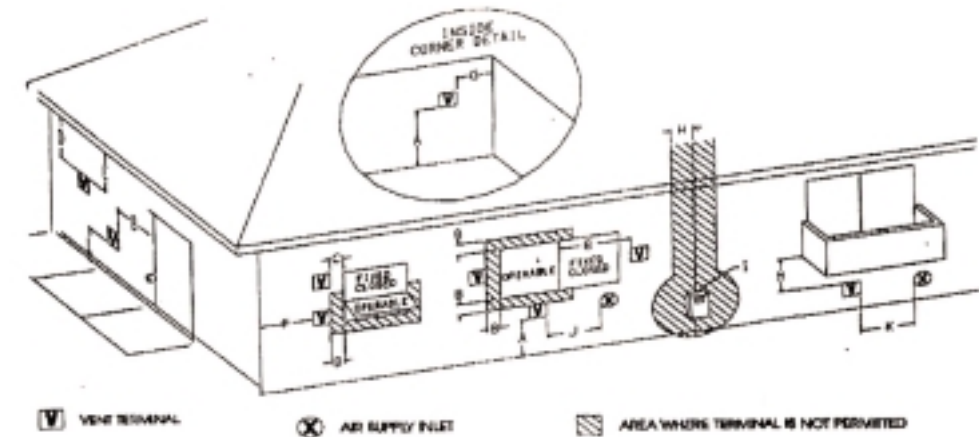

	Canadian installations ¹	US installations ²
A= Clearance above grade, veranda, porch, deck, or balcony	12 inches (30cm)	12 inches (30cm)
B= Clearance to window or door that may be opened	6 inches (15cm) for appliances ≤ 10,000 Btuh (3kW), 12 inches (30cm) for appliances > 10,000 Btuh (3kW) and ≤ 100,000 Btuh (30kW), 36 inches (91cm) for appliances > 100,000 Btuh (30kW)	6 inches (15cm) for appliances ≤ 10,000Btuh (3kW), 9 inches (23cm) for appliances > 10,000Btuh (3kW) and ≤ 50,000Btuh (15kW), 12 inches (30cm) for appliances > 50,000 Btuh (15kW)
C= Clearance to permanently closed window	π	π
D= Vertical clearance to ventilated soffit located above the terminal within a horizontal distance of 2 feet (61cm) from the centre line of the terminal	π	π
E= Clearance to unventilated soffit	π	π
F= Clearance to outside corner	π	π
G= Clearance to inside corner	π	π
H= Clearance to each side of centre line extended above meter/regulator assembly	3 feet (91cm) within a height 15 feet (4.5m) above the meter/regulator assembly	π
I= Clearance to service regulator vent outlet	3 feet (91cm)	π
J= Clearance to non-mechanical air supply inlet to building or the combustion air inlet to any other appliance	6 inches (15cm) for appliances ≤ 10,000Btuh (3kW), 12 inches (30cm) for appliances > 10,000Btuh (3kW) and ≤ 100,000Btuh (30kW), 36 inches (91cm) for appliances > 100,000 Btuh (30kW)	6 inches (15cm) for appliances ≤ 10,000Btuh (3kW), 9 inches (23cm) for appliances > 10,000Btuh (3kW) and ≤ 50,000Btuh (15kW), 12 inches (30cm) for appliances > 50,000 Btuh (15kW)
K= Clearance to a mechanical air supply inlet	6 feet (1.83m)	3 feet (91cm) above it within 10 feet (3m) horizontally
L= Clearance above paved sidewalk or paved driveway located on public property	7 feet (2.13m) †	π
M= Clearance under veranda, porch, deck or balcony	12 inches (30cm) ‡	π

¹ In accordance with the current CSA B149.1, Natural Gas and Propane Installation Code
² In accordance with the current ANSI Z223.1/NFPA 54, Natural Fuel Gas Code
† A vent shall not terminate directly above a sidewalk or paved driveway that is located between two single family dwellings and serves both dwellings
‡ Permitted only if veranda, porch, deck or balcony is fully open on a minimum of two sides beneath the floor
π For clearances not specified in ANSI Z223.1/NFPA 54 or CSA B149.1, one of the following shall be indicated:
a) A minimum clearance value determined by testing in accordance with section 2.19.6 or;
b) A reference to the following footnote:
"Clearance in accordance with local installation codes and requirements of the gas supplier."

Termination Clearances

Termination clearances for buildings with combustible and non-combustible exteriors.

Figure 9. Vent termination clearances.

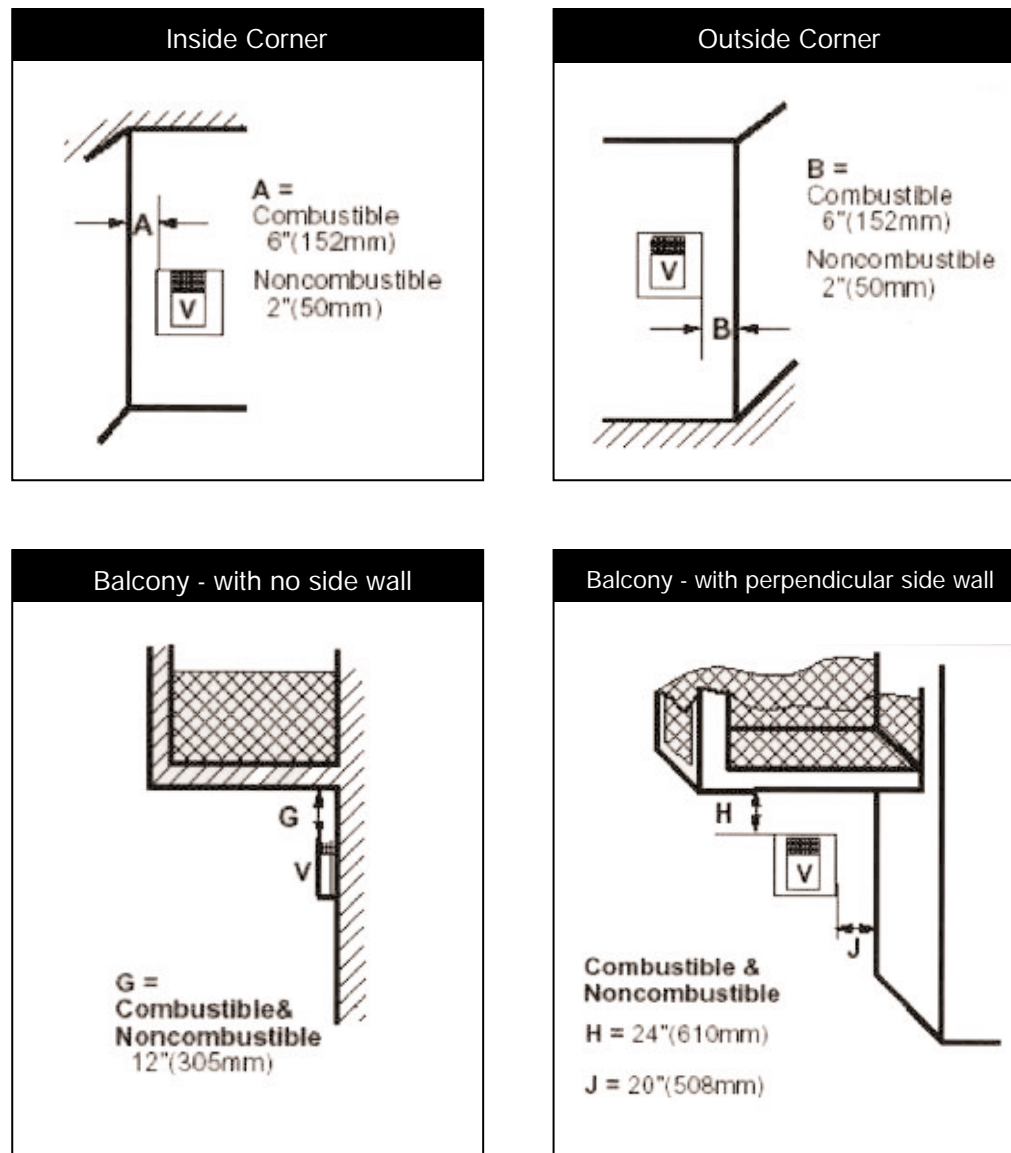

Remove the Log Set

The Log Set is inside the firebox in a protective package.

The Glass Panel must be removed to install the Log Set in the firebox.

- Lift off the top panel and place to one side. Remove the securing nut and lift off the front casting and place on one side.
- Swing open the swiveling latches at the top left and right corners of the glass frame - see figure below.
- Pull the top edge of the glass and frame assembly away from the firebox, and lift it off its supports on the bottom of the firebox face. Place the assembly out of the way on a flat, padded surface such as a counter protected by a towel.
- Take the log set and all other loose parts out of the firebox, and set them aside in a protected spot, for installation after the venting is complete.

NOTE: Verify the explosion relief door (located at the back of the firebox, see fig.1) is properly seated on the gasket. The door should sit flush on the gasket. Grip the relief door and gently lift against the springs to ensure the door lifts off the gasket. Then release.

Failure to position the parts in accordance with these diagrams or failure to use only parts specifically approved for use with this heater may result in property damage or personal injury.

This heater and components are heavy. Have help available for assembly.

WARNING Porcelain enamelled surfaces are fragile. Handle porcelain enamelled castings with care.

Before you begin assembly, read this section of the manual to familiarize yourself with the procedures.

The installation will be easiest if you follow the steps in the order presented.



Fig 10.
Swivel the latches to release the glass frame.

Assembly Procedures

Venting System Assembly - Direct Vent

The Dragon/700 is approved for installation only with the vent components previously listed in the VENTING REQUIREMENTS section. Follow the vent component instructions exactly. For U.S. installations: The venting system must conform with local codes and/or the current National Fuel Gas Code, ANSI Z223.1 For Canadian installations: The venting system must conform to the current CSA B149.1 installation code.

Install Restrictor Plate

Install the Restrictor Plate. Consult the 'Vent Run Specifications' to determine whether the restrictor plate is needed. If so, put the restrictor plate in place within the inner flue collar as shown below.

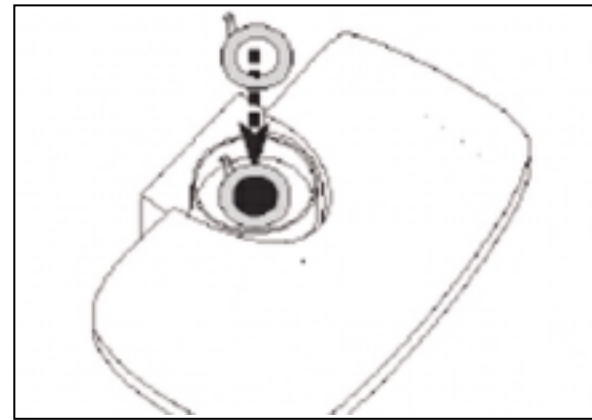
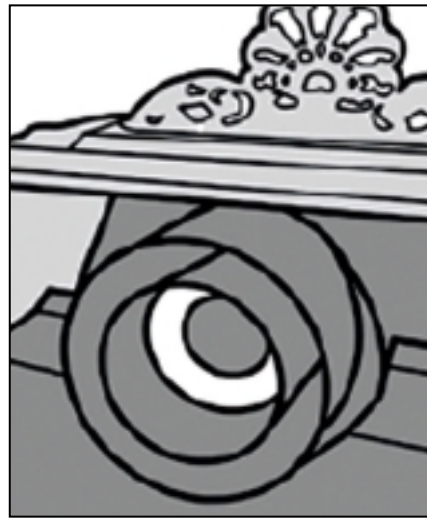
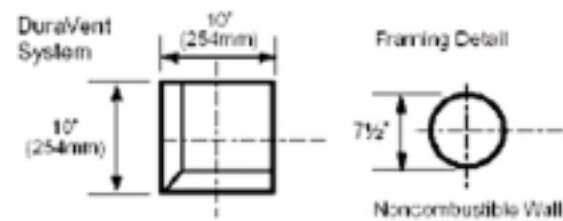

Fig 11. Install the restrictor plate only if required for the venting configuration.

Side Wall Termination Assembly

1. Locate the vent opening on the wall. It may be necessary to first position the stove and measure to find the hole location. Depending on whether the wall is made of combustible materials, cut the opening to the size shown below. Combustible wall openings must be framed as shown below.



For DuraVent pipe only:

- Install vent pipe by aligning the locking system together, sliding the pipes together and twisting clockwise.
- Install 90° elbow. Twist lock as before.
- Slide the wall plate over horizontal run before attaching the horizontal run to the elbow. Fasten wall plate to wall.

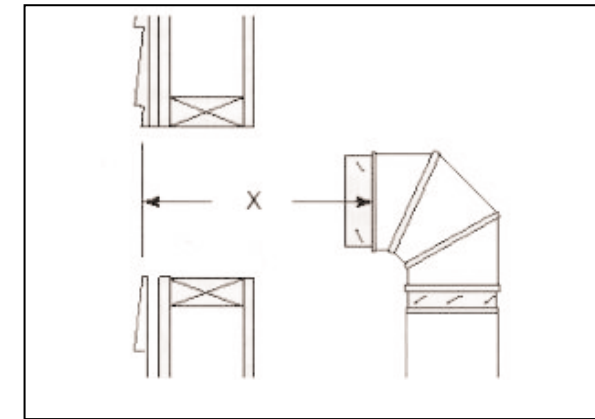

Fig 13. Measure the horizontal length.

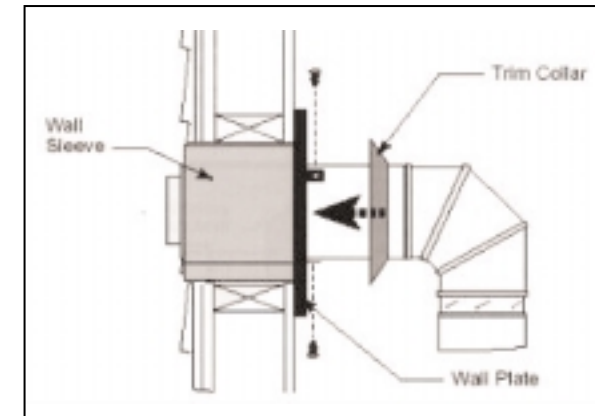

Fig 12. Install the horizontal pipe and wall plate parts.

For DuraVent/Selkirk Systems: Install the vent terminal. Apply high temperature sealant one inch from the ends of the inner and outer collars. Guide the inner and outer vent termination collars into the adjacent pipes. Double check that the vent pipes overlap the collars by 2". Fasten the termination to the wall with the screws provided, and caulk the joint with weatherproof sealant.

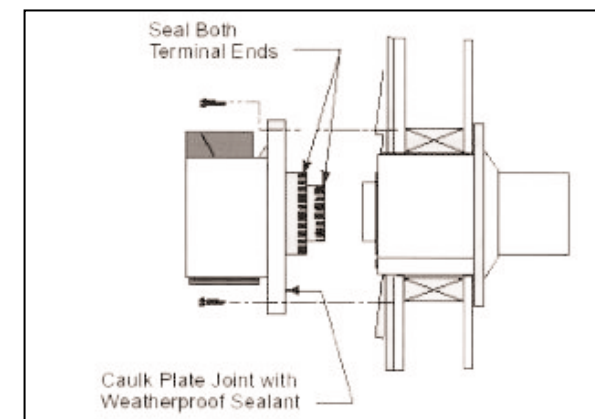

Fig 13. Install the vent terminal.

Vent Termination Below Grade

Install Snorkel Kit when it is not possible to meet the required vent termination clearances of 12" (305mm) above grade level. The snorkel kit will allow installation depth of down to 7" (178mm) below grade level. The seven inches is measured from the center of the horizontal vent pipe as it penetrates the wall. If the venting system is installed below grade, a window well must be installed with adequate and proper drainage. (Fig. 14)

NOTE: Be sure to maintain side wall clearances and vent run restrictions. Refer to Figures 3 through to 9.

1. Establish the vent hole through the wall.
2. Remove soil to a depth of approximately 16" (400mm) below the base of the snorkel. Install a window well (not supplied). Refill the hole with 12" (305mm) of coarse gravel and maintain a clearance of at least 4" (100mm) below the snorkel. (Fig. 14)
3. Install the vent system as described on previous pages.
4. Be sure to make a watertight joint around the vent pipe joint at the inside and outside wall joints.
5. Apply high temperature sealant around the inner and outer snorkel collars. Join the pipes and fasten the snorkel termination to the wall with the screws provided.
6. Level the soil to maintain a 4" clearance below the snorkel. If the foundation is recessed, use extension brackets (not supplied) to fasten the lower portion of the snorkel. Fasten the brackets to the wall first, and then fasten to the snorkel with self-tapping #8 x 1/2" sheet metal screws. Extend the vent pipes out as far as the protruding wall face.

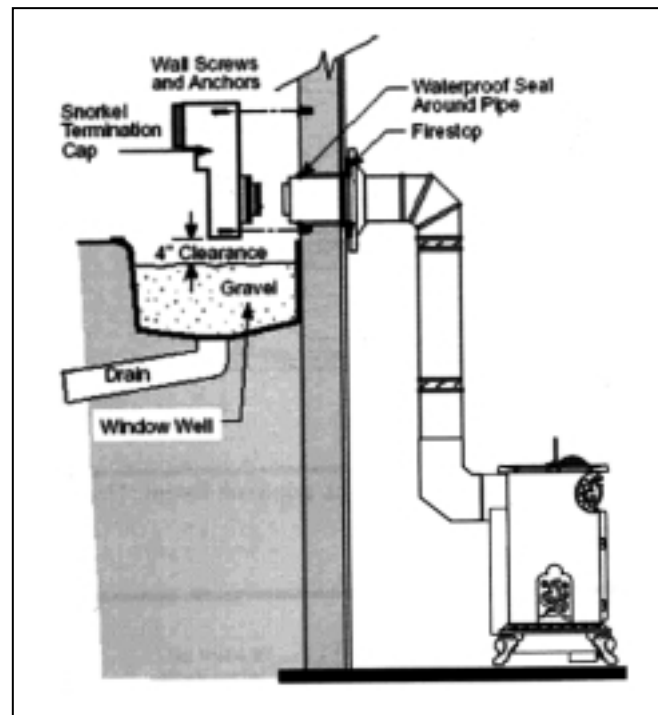

Fig 14. Snorkel kit installation.

Vertical (Through the Roof) Vent Assembly

NOTE: All vertically terminated installations must include the restrictor plate included with the stove. Make certain the vent system conforms to all other requirements for vertical termination as specified.

This installation will require you to first determine the roof pitch and use the appropriate vent components. Refer to Figures 14 and 16

1. Locate the final position of the stove, observing all clearances for both the vent and the stove.
2. Plumb to the center of the inner (4") flue collar from the ceiling above, and mark that location.
3. **Cut the opening: DuraVent System: 10" x 10" (254mm x 254mm)**
4. Plumb any additional opening through the roof or other construction that may be needed. In all cases, the opening must provide a minimum of 1" (25mm) clearance to the vent pipe.
5. Place the stove in its final position.

6. Install firestop(s) and Attic Insulation Shield as needed. (Fig. 15) If there is a room above ceiling level, a firestop must be installed on both the bottom and top sides of the ceiling joists. If an attic is above ceiling level, an attic insulation shield must be installed.
7. Install the appropriate roof support and flashing, making certain that the upper flange of the flashing base is below the shingles. (Fig. 15)
8. Install appropriate pipe sections until the vent run reaches above the flashing. The enlarged ends of the vent sections always face downward.
9. Install the storm collar and seal around the joints. (Fig. 16)
10. Add additional vent lengths to achieve the proper overall height.
11. Apply cement to the inner and outer termination collars and install the terminal cap.

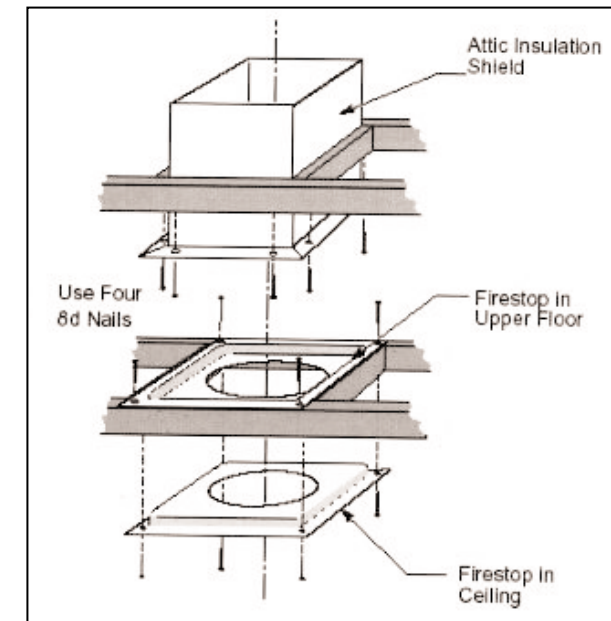

Fig 15. Install firestops and attic insulation shield.

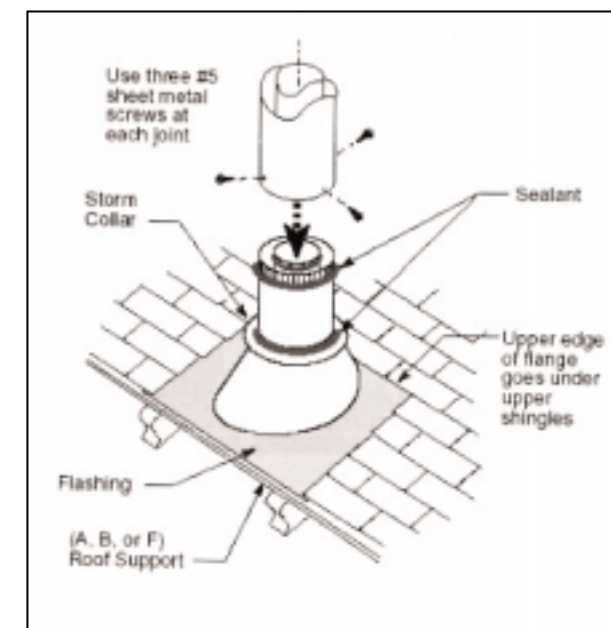
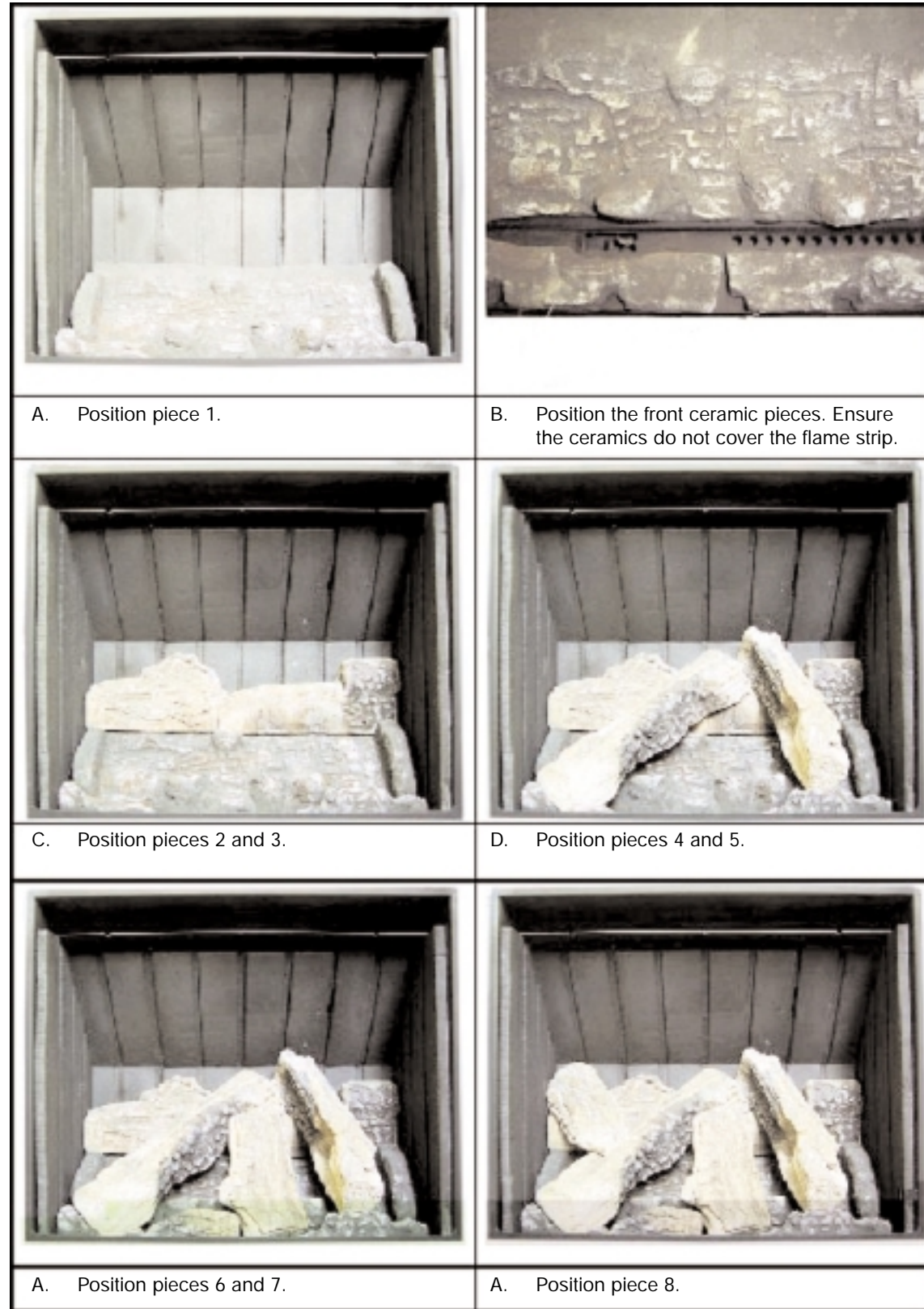

Fig 16. Roof support and flashing.

Installing the Log Set

Remove the logs from their packaging and inspect each piece for damage.
DO NOT INSTALL DAMAGED LOGS.



Connect the Gas Supply Line

Check the Rating Plate attached by a cable to the firebox, to confirm that you have the appropriate firebox for the type of fuel to be used. The Dragon/700 stove may be converted from one gas to another using the appropriate Fuel Conversion Kit.

CAUTION

This appliance should only be connected by a qualified gas technician. Test to confirm manifold pressures as specified below. The Dragon/700 stove and its individual shutoff valve must be disconnected from the gas supply piping during any pressure testing of that system at test pressures in excess of 1/2 psig (3.5 kPa).

The Dragon Heater must be isolated from the gas supply piping system by closing its individual manual shutoff valve during any pressure testing of the gas supply piping system at test pressure equal to or less than 1/2 psig.

There must be a gas shutoff between the stove and the supply. In order to connect Natural Gas, use a fitting with 3/8" NPT nipple on the valve side and 1/2" natural gas supply line with an input of 26,500 BTUs at a manifold pressure of 3.5" and minimum inlet supply for adjustment of 4.5" w.c.

In order to connect Propane, use a fitting with 3/8" NPT nipple on the valve side and 1/2" propane gas supply line with an input of 23,000 BTUs at a manifold pressure of 10.5" and minimum inlet supply for adjustment of 11.0" w.c.

In the U.S.: Gas connection should be made in accordance with current National Fuel Gas Code, ANSI Z223.1. Since some municipalities have additional local codes, be sure to consult your local authority.

In Canada: consult the local authority and CSA-B149.1 installation code.

Always check for gas leaks with a mild soap and water solution. Do not use an open flame for leak testing. Light the pilot according to these instructions, before going to the next step.

Burner Information

The appliance must only use the gas specified on the rating plate, unless converted using a ESSE Fuel Conversion Kit. To convert from LP to Natural Gas use Kit. To convert from Natural Gas to LP use Kit. Conversion instructions are provided with each kit.

THIS APPLIANCE SHOULD BE CONNECTED TO THE GAS SUPPLY ONLY BY A QUALIFIED GAS SERVICE TECHNICIAN. FOLLOW ALL LOCAL CODES. THERE MUST BE A GAS SHUT-OFF BETWEEN THE STOVE AND THE SUPPLY.

Your First Fire

Read these instructions carefully and familiarize yourself with the burner controls. Locate the pilot assembly, shown below. Follow the lighting instructions on the next page exactly. During the first fire, it is not unusual to smell some odor associated with new logs, paint and metal being heated. Odors should dissipate within an hour or so, however, you can open a window to provide fresh air to alleviate the condition.

Pilot and Burner Inspection

Each time you light your heater check that the pilot flame is as shown below and the burner flame is as shown in figure 20. If flame patterns are incorrect, turn the heater off. Contact your dealer or a qualified gas technician for assistance. Do not operate the heater until the pilot flame is correct. Follow regular maintenance procedures as described in these instructions.

Flame Characteristics

It is important to periodically perform a visual check of the pilot and the burner flames. Compare them to the figures below. If the flame appears abnormal, call a service person.

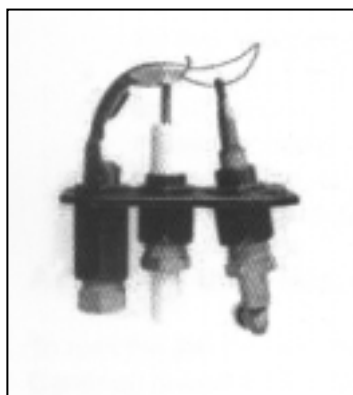

FOR YOUR SAFETY READ BEFORE LIGHTING

WARNING: If you do not follow these instructions exactly, a fire or explosion may result causing property damage, personal injury or loss of life.

- A. This stove has a pilot that must be lit manually. When lighting the pilot follow these instructions exactly.
- B. BEFORE LIGHTING smell all around the fireplace area for gas. Be sure to smell next to the floor because some gas is heavier than air and will settle on the floor.

What to do if you smell gas

Do not try to light any fireplace
 Do not touch any electric switch
 Do not use any phone in your building
 Immediately call your gas supplier from a neighbour's phone. Follow the gas supplier's instructions.
 If you cannot reach your gas supplier, call the Fire Department.

- C. Use only your hand to push in or turn the gas control knob. Never use tools. If the knob will not push in or turn by hand do not try to repair it, call a qualified service technician. Force or attempted repair may result in a fire or explosion.
- D. Do not use this stove if any part has been under water. Immediately call a qualified service technician to inspect the stove and to replace any part of the control system and any gas control that has been under water.

Lighting Instructions

1. STOP! Read the safety information above.
2. Swing open control access panel.
3. Push in gas control knob slightly and turn clockwise ↻ to 'OFF' (Knob A)

NOTE: Knob A cannot be turned from 'PILOT' to 'OFF' unless knob is pushed in slightly. Do not force.

4. Wait five (5) minutes to clear out any gas. Then smell for gas, including near the floor. If you smell gas STOP and follow point B in the safety information above. If you don't smell gas go to the next step.
5. Turn knob A (figure 1) counter clockwise ↻ towards the ignition position (IGN) until reaching stop, press down and hold for five seconds (only pilot gas flows). Continue pressing down knob A while turning further counter clockwise ↻ to activate piezo, continue to hold down for ten seconds after pilot burner has been lit. If pilot does not light, steps 1 and 2 can be repeated immediately. Upon lighting, release knob and turn further counter clockwise ↻ to ON position. Pilot gas flows and main gas flows in accordance to the temperature setting knob B).

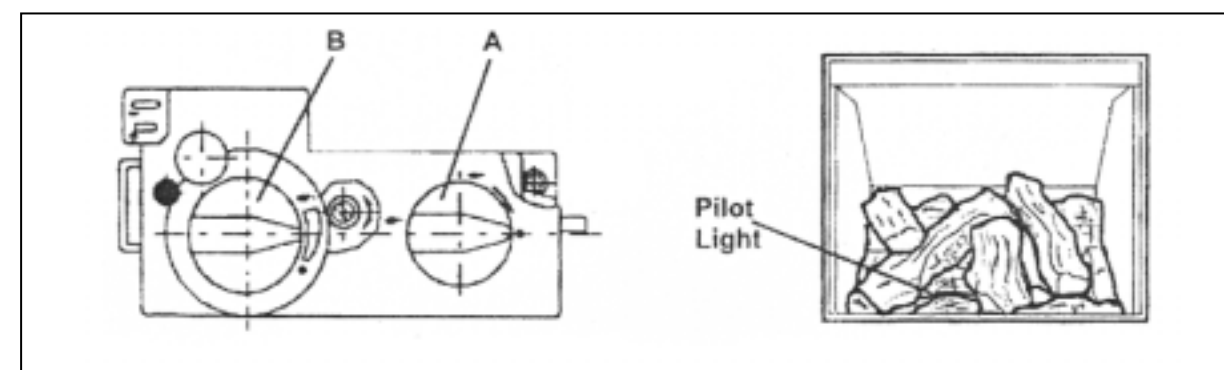

Figure 1.

Adjusting the Flame Height

To turn the fire on and/or to increase the flame height, press the ON button of the remote handset. Continue pressing until the desired flame height is obtained. Press and hold the OFF button to reverse the procedure.

The receiver is equipped with a built-in delay, recognisable by the flickering light, to facilitate fine adjustment of the flame. The motorised valve is equipped with a slip clutch, allowing manual adjustment of main gas by turning knob B. Set the desired programme and temperature on the handset as described in the instruction manual.

To Turn Off Gas to Stove

Turn knob A clockwise until reaching stop. In this position only pilot gas flows. To shut off the valve completely, press down slightly and continue to turn clockwise from pilot position to the OFF position. The safety interlock prevents re-ignition of the pilot flame until the thermocouple has cooled down sufficiently (elapsed time will vary based on thermocouple type). Switching off the remote is not necessary.

Remote Control

Set the display

- After connecting the battery or by simultaneously pressing **AUTO** and **TIMER**, the display flashes. You are in set mode.
- From set mode, press **AUTO** to switch from °F (and 12 hour clock) to °C (and 24 hour clock) or vice versa.
- The display will automatically return to manual after some time, but you may immediately return to manual by depressing the **TIMER** button.

Set the current time

- After connecting the battery or by simultaneously pressing **AUTO** and **TIMER**, the display flashes. You are in set mode.
- From set mode, press (2%) to set the hour and (1/4%) to set the minute.
- Wait or press **TIMER** to return to "manual" mode.

Programming the Desired Set Temperature

- Press **AUTO** until the display flashes.
- Press (2%) or (1/4%) to set the desired temperature.
- Wait or press **AUTO** to switch to automatic mode.
- A sensor in the transmitter measures the room temperature. The controller compares the room temperature with the set temperature and sends a signal to the receiver to turn the gas valve motor, which adjusts the flame height accordingly.

Programming the Timer

- Press **TIMER** until **P1*** flashes (period 1, heating cycle on).
- Set the time for the beginning of the first heating period by pressing (2%) for hour and (1/4%) for minute.
- Press **TIMER** again; **P1w** appears.
- Set the time for end of the first heating period.
- Press **TIMER** again to set the second heating period **P2w** (heat off).
- Store both heating periods by pressing **TIMER** again.
- If only one heating period is desired, program the same time for **P2*** and **P2w**.

Manual Mode (MAN in display) for Manual Flame Height Adjustment

- Press (2%) to turn on the fire (main burner) or to increase flame height.
- Press (1/4%) to decrease flame or to turn down to pilot.
- To incrementally increase or decrease the flame height lightly tap either the (2%) or (1/4%) button.
- The "send" symbol appears in the upper left corner of the display when either button is depressed.
- The LED of the receiver flashes when knob B of the valve reaches the end stops.

Automatic Mode (AUTO in display) for Temperature Control

- Briefly press **AUTO**. The set temperature will appear briefly before the display reverts to the room temperature.

Timer Mode (TIMER in display)

- During heating periods **P1*** and **P2***, the temperature is controlled in the same manner as in automatic mode.
- When the timer program turns to w (heating cycle off), the motor will turn the valve to pilot and there is no temperature control. This minimises battery consumption.

- You may press **AUTO** to verify the set-temperature and then press **TIMER** to return to timer mode.
- You may press either the (2%) or (1/4%) button from any mode for manual override.
- To prolong battery life, we recommend switching the transmitter to manual mode and turning the fire to pilot with the (1/4%) button before turning the appliance off. If the transmitter is left in automatic or timer mode, the batteries will continue to be used when the appliance is off.

Changing the Battery

- If **BATT** appears in upper right hand corner of the display or if the LED of the receiver becomes faint, please change the battery from transmitter or receiver. If the batteries lose power, the flame height can be adjusted by manually turning knob B.

NOTE

Please note, the placement of the transmitter (temperature sensor) is important to assure proper temperature regulation. Generally, a more constant temperature will be assured, if the transmitter is not too far from the gas appliance. Before switching to **AUTO** or **TIMER** mode, press either button (2%) or (1/4%) to verify the reception (when the send symbol appears in the transmitter display, the receiver's LED must illuminate). For the **AUTO** or **TIMER** mode to function correctly, the transmitter must remain within range of the receiver. The transmitter should not be used in very close proximity to the receiver (less than 1m/3ft) as this could, in very rare cases, produce a electronic switching error. This error could block the motor when the knob reaches the end points of its turning radius. The knob must then be turned manually to free the blockage.

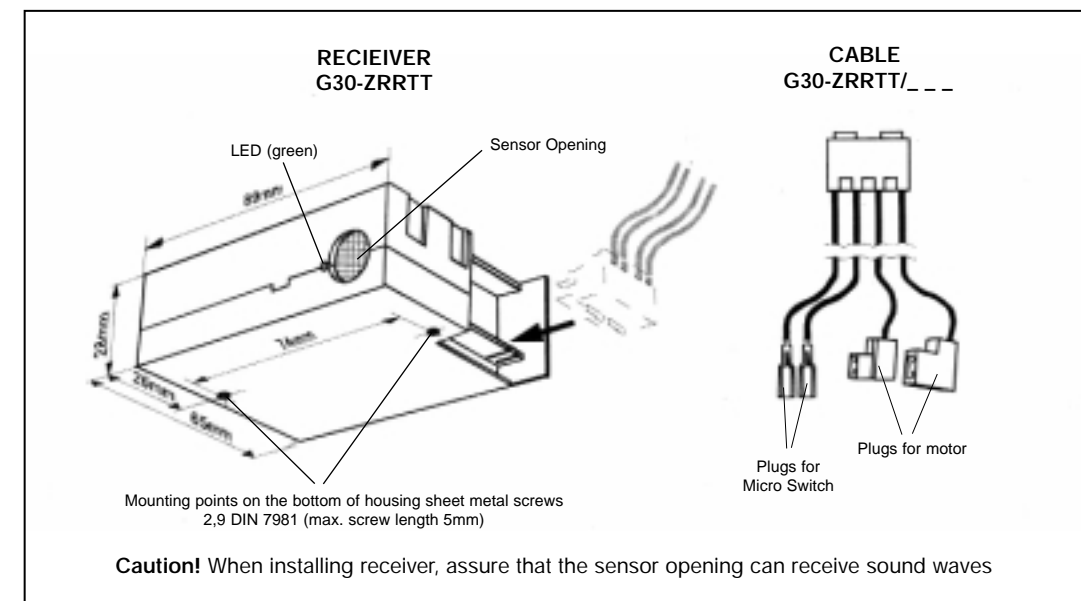
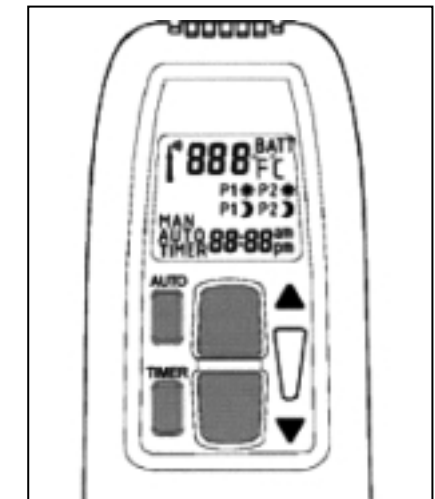
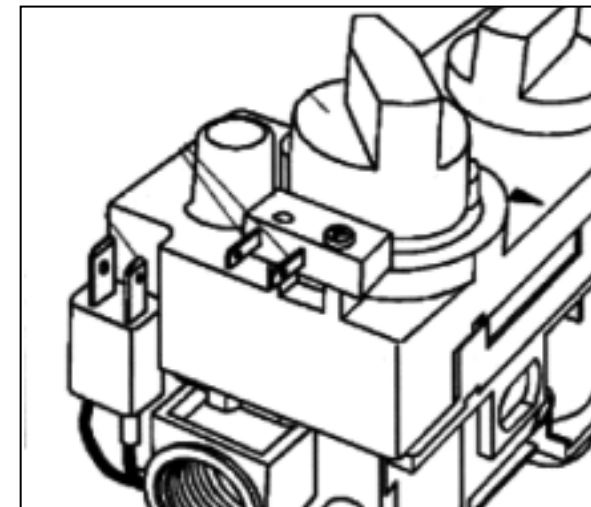

Maintenance

Your Dragon/700 Gas Heater will provide years of service with minimal upkeep. The following procedures will help ensure that your stove continues to function properly.

Annual System Inspection

Have the entire heater and venting system inspected annually by a qualified gas technician. Replace any worn or broken parts.

Logset and Burner

Cleaning and Inspection

Cleanliness is critical to the proper function of the heater. The logset and burner must all be kept free of dust and unobstructed by debris. Inspect these areas before each use and clean as necessary.

1. Turn the burner OFF and let the heater cool completely before cleaning.
2. Remove the top casting. Lift the stove front up and then swing the bottom out to disengage it from the heater shell.
3. Carefully remove the glass and frame assembly and place it out of the way on a flat, padded surface such as a counter protected by a towel.
4. Carefully inspect the logs for damage. Contact your local dealer if any damage is evident.
DO NOT OPERATE THE HEATER WITH DAMAGED LOGS.
5. Use a soft bristled brush to sweep dust or debris from the logs, pilot burner orifice and Burner. Use care as the logs are fragile and susceptible to damage.
DO NOT USE A VACUUM TO CLEAN THE LOGS OR BURNER.
6. Replace the glass panel and frame assembly.
7. Replace the stove front and top.

Care of Cast Iron

An occasional dusting with a dry rag will help keep the painted surfaces looking new. Use high-temperature stove paints, available through your local dealer, to touch-up areas as needed. Clean areas to be painted with a wire brush and be sure to cover the logs, burner and valve assembly, glass and frame assembly. Apply the paint sparingly; two light coats of paint will give better results than a single heavy coat. Clean porcelain enamel surfaces with a soft, damp cloth. Do not use abrasive cleaning agents. If necessary, use only a cleaning agent formulated especially for use on porcelain enamel surfaces.

CAUTION

TURN THE PILOT OFF BEFORE PAINTING. ALLOW THE HEATER TO COOL COMPLETELY BEFORE PAINTING.

Cleaning the Glass

WARNING: Allow the glass to cool completely before attempting to clean.

It will be necessary to clean the glass periodically. During start-up, condensation, which is normal, forms on the inside of the glass and causes lint, dust and other airborne particles to cling to the glass surface. Also initial paint curing may deposit a slight film on the glass. It is therefore recommended that the glass be cleaned two or three times with a non-ammonia household cleaner and warm water (we recommend gas fireplace glass cleaner). Do not use an abrasive cleaner. After that the glass should be cleaned two or three times during each heating season depending on the circumstances present.

Clean glass after first two weeks of operation.

Glass Replacement

Replace glass only with ESSE approved parts. Refer to Replacement Parts towards the back of this manual. Refer to previous instructions for removal of the damaged glass frame.

Inspect the Vent System Annually

Have the vent system inspected annually by a qualified technician. Shut off the main gas supply before inspecting the system. Both the inner exhaust pipe and the outer combustion supply pipe must be checked to confirm that they are unblocked and in good condition.



Fig 19. Remove the stove top and front, then swivel the latches to release the glass frame.



Fig 20. Correct flame pattern.

Check the Gas Flame Regularly

To ensure that the stove is operating properly, check the flames periodically to confirm that they match Figure 20. The flames will be blue during the first 15-20 minutes of operation, and will gradually turn to yellow after that. Do not use your stove if the flame pattern differs from that shown here. Contact your **esse** dealer or a qualified technician for help.

Dragon/700 Components

ITEM NO.	QTY.	PART NO.
1	1	balanced box1 ASSEMBLY MKII
2	1	swing door
3	1	dragon dv side tie
4	1	front casting tie
5	1	dragon hinge plate
6	1	dragon top casting
7	1	dragon front
8	1	MirrorDragon hinge plate
9	1	bra assembly
10	1	dragon badge
11	1	dragon door
12	1	MirrorDragon door
13	1	dragon base
14	1	Dragon side
15	1	MirrorDragon side
16	4	dragon foot
17	2	dragon spinner
18	1	window assembly
19	1	heat shield
20	1	burner1 ASSEMBLY
21	1	receiver
22	1	MAXITROL VALVE
23	1	baffle MKII
24	1	brick assembly
25	1	log assembly

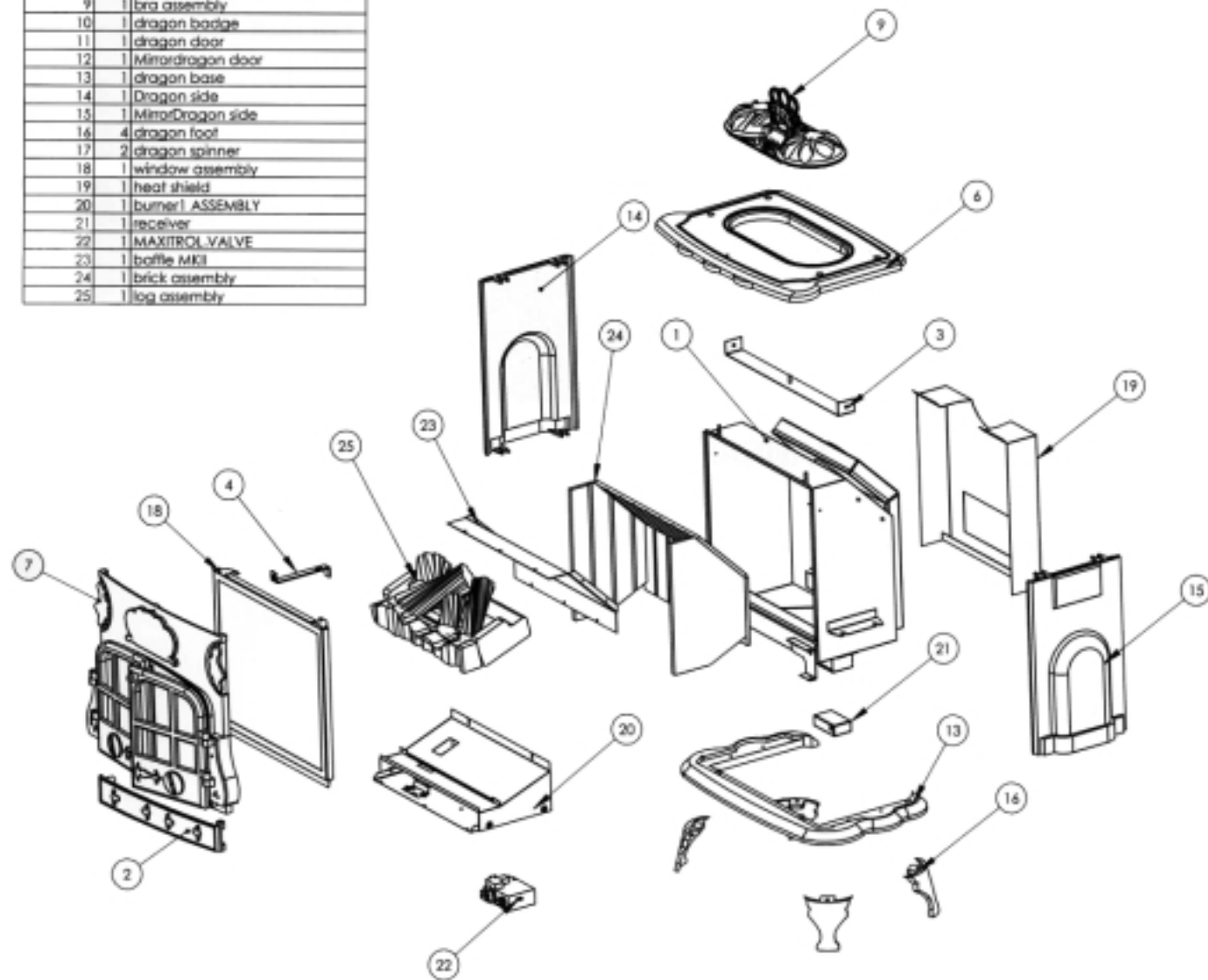

THE AUTHENTIC ORIGINAL

ESSE NORTH AMERICA
 Tel: (250) 743-2221
 Fax: (250) 743-1229

Ouzledale Foundry Co Ltd., Long Ing, Barnoldswick, Lancashire. BB18 6BN. England

Tel: 011 44 1282 813235

Fax: 011 44 1282 816876

e-mail enquires@ouzledale.co.uk

Web site address: <http://www.esse.com>